

Description

Compact single pole thermal circuit breaker with push-to-reset, tease free, trip free, snap action mechanism and separate (colour coded) manual release. Combining full feature circuit breaker protection and convenience with low cost of ownership benefits. Fitted with blade terminals for plug-in mounting.

Type III to SAE J 553.

Version 1176 is available especially for the automotive industry (current ratings correspond to those of blade fuses).

Typical applications

Extra low voltage wiring systems on all types of vehicles and marine craft.

Ordering information

| | |
|--|--|
| Type No. | |
| 1170 | plug-in |
| Design standard | |
| 21 | blade terminals for automotive fuse blocks (standard) with retaining clips |
| 22 | blade terminals for automotive fuse blocks, without retaining clips |
| Current ratings | |
| 3...25 A | |
| 1170 - 21 - 15 A ordering example | |

Standard current ratings, typical voltage drop values and actuator colours (manual release)

| Current rating (A) | Voltage drop (mV) | Actuator colour |
|--------------------|-------------------|---------------------------------------|
| 3 | < 300 | violet (approximating RAL 4008) |
| 4 | < 300 | pink (approximating RAL 3015) |
| 5 | < 300 | orange-brown (approximating RAL 8023) |
| 6 | < 150 | mossy-green (approximating RAL 6005) |
| 7.5 | < 150 | hazel (approximating RAL 8011) |
| 8 | < 150 | honey (approximating RAL 1005) |
| 10 | < 150 | red (approximating RAL 3020) |
| 15 | < 150 | blue (approximating RAL 5012) |
| 20 | < 150 | yellow (approximating RAL 1018) |
| 25 | < 150 | pearl (approximating RAL 1013) |



1170-...

Technical data

| | |
|--|---|
| Voltage rating | DC 28 V |
| Current ratings | 3...25 A (30 A upon request) |
| Typical life | at rated current: 3...25 A 6,000 operations at I_N 3...20 A 3,000 operations at $2 \times I_N$ 25 A 1,000 operations at $2 \times I_N$ |
| Ambient temperature | -40...+85 °C (-40...+185 °F) |
| Interrupting capacity I_{cn} | 400 A |
| Ultimate short-circuit breaking capacity | ≥ 1 break operation at 2,000 A |
| Degree of protection (IEC 60529/DIN 40050) | operating area IP40 terminal area IP00 |
| Vibration | 10 g (57-500 Hz) \pm 0.76 mm (10-57 Hz), to IEC 60068-2-6, test Fc, 10 frequency cycles/axis |
| Shock | 50 g (11 ms) to IEC 60068-2-27, test Ea |
| Corrosion | 96 hours at 5 % salt mist, to IEC 60068-2-11, test Ka |
| Humidity | 240 hours at 95 % RH to IEC 60068-2-3, test Ca |
| Mass | approx. 13 g |

Dimensions

1170-21

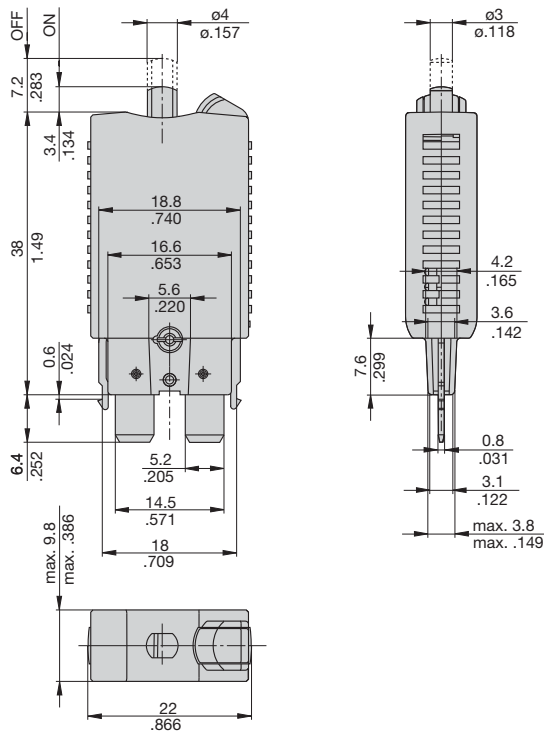

1170-22

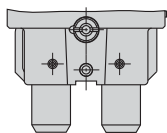

Internal connection diagram

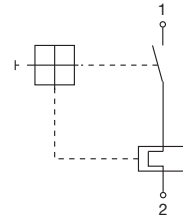

Typical time/current characteristics at +23°C/73.4°F

3 ... 25 A

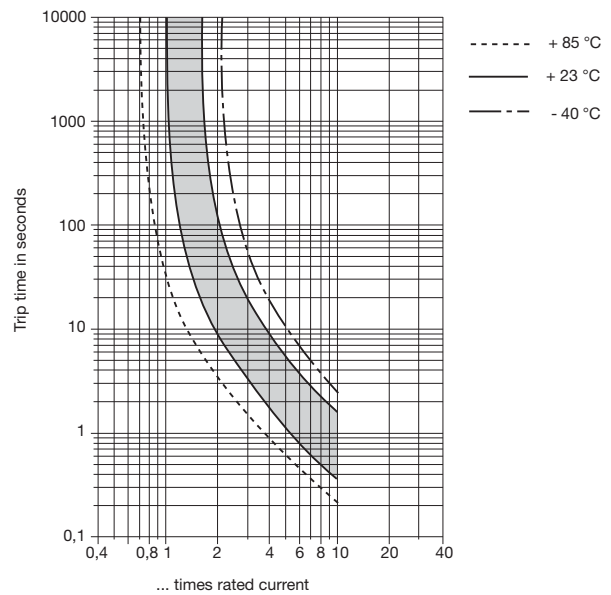

The time/current characteristic curve depends on the ambient temperature prevailing. In order to eliminate nuisance tripping, please multiply the circuit breaker current ratings by the derating factor shown below. See also section 9 – Technical information.

| | | | | | | |
|------------------------|-------|------|------|------|------|------|
| Ambient temperature °F | -40 | -22 | -4 | +14 | +32 | +50 |
| Ambient temperature °C | -40 | -30 | -20 | -10 | 0 | +10 |
| Derating factor | 0,77 | 0,80 | 0,84 | 0,89 | 0,94 | 0,96 |
| Ambient temperature °F | +73.4 | +104 | +122 | +140 | +158 | +185 |
| Ambient temperature °C | +23 | +40 | +50 | +60 | +70 | +85 |
| Derating factor | 1 | 1,08 | 1,16 | 1,24 | 1,33 | 1,42 |

Accessories

Socket 12-P10

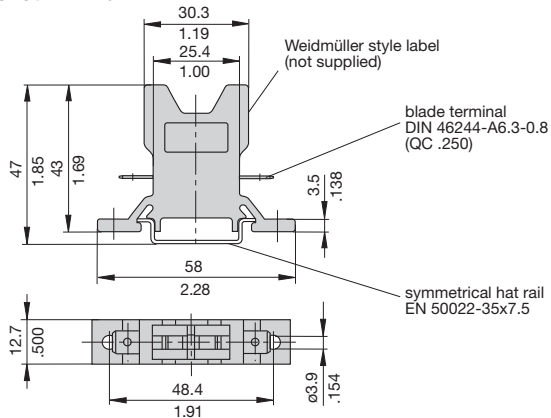

Socket 12-J20

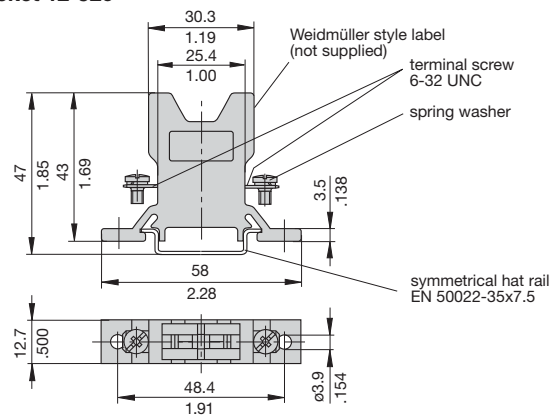

Socket 12-A10

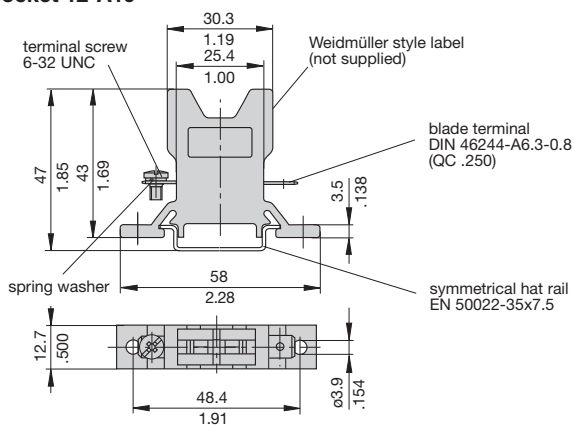

Dimensions for surface mounting

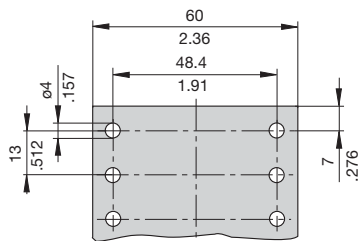

Other sockets available to special order
Labels: Weidmüller, D-33102 Paderborn

Ordering information Mounting socket 12

Type No.

12 Mounting socket

Terminal design

P10 blade terminals A6.3-0.8 (QC .250)

J20 screw terminals 6-32 UNC

A10 1 blade terminal A6.3-0.8 (QC .250)/1 screw terminal 6-32 UNC

Version

(blank) single socket

20 two-way

30 three-way

40 four-way

60 six-way

12 - P10 - 20 ordering example

Accessories for mounting socket 12

Connector bus links -P10

X 210 588 01/ 1.5 mm² (AWG 16), brown (up to 13 A max. load)

X 210 588 02/ 2.5 mm² (AWG 14), black (up to 20 A max. load)

X 210 588 03/ 2.5 mm² (AWG 14), red (up to 20 A max. load)

X 210 588 04/ 2.5 mm² (AWG 14), blue (up to 20 A max. load)

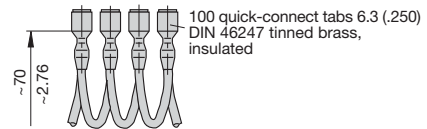

Bus bar (supplied as a complete package)

(up to 100 A max. load)

X 211 157 01 with terminal

X 211 157 02 without terminal

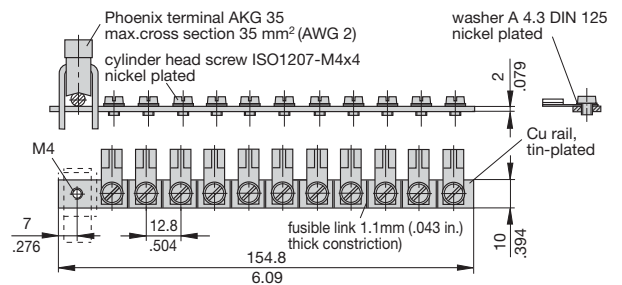

This is a metric design and millimeter dimensions take precedence ($\frac{\text{mm}}{\text{inch}}$)

All dimensions without tolerances are for reference only. In the interest of improved design, performance and cost effectiveness the right to make changes in these specifications without notice is reserved. Product markings may not be exactly as the ordering codes. Errors and omissions excepted.